

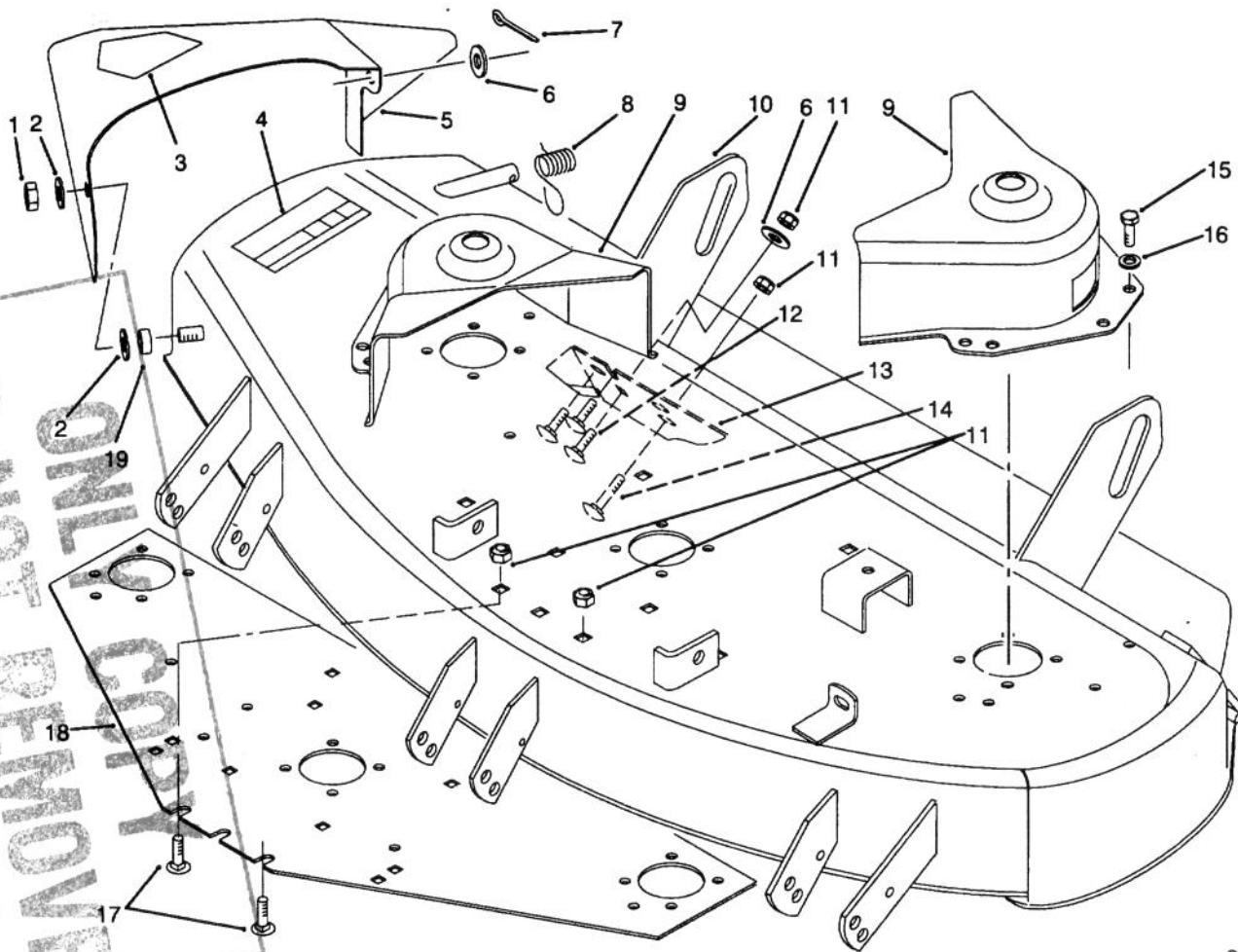

MODEL NO. 78230-3900001 & UP

PARTS CATALOG

42" (107cm) Cutting Unit (Yard Tractors)  
WHEEL HORSE®



DO NOT REMOVE  
ONLY COPY  
Tech. Publications

C-1675

DECK ASSEMBLY

Ref. No.	Part No.	Description	No. Used
1	915236	Nut - Jam	1
2	116083	Washer - Nylon	2
3	54-9220	Decal - Danger	1
4	66-1340	Decal - Danger	1
5	88-2750	Chute/Decal Assembly	1
6	3256-26	Washer - Flat	4
7	3272-10	Pin - Cotter	1
8	116082	Spring - Deflector	1
9	78-6891	Cover - Belt	2
10	92-8014	Deck/Safety Decal Assy.	1

Ref. No.	Part No.	Description	No. Used
11	3296-39	Nut - Lock	9
12	3231-22	Bolt - Carriage	3
13	79-2831	Wear Plate - R.H.	1
14	3231-5	Bolt - Carriage	2
15	926671	Screw - Cap Hex. Hd.	4
16	3256-22	Washer - Flat	4
17	3231-1	Bolt - Carriage	4
18	78-8530	Plate - Reinforcement	1
19	116080	Bushing	1

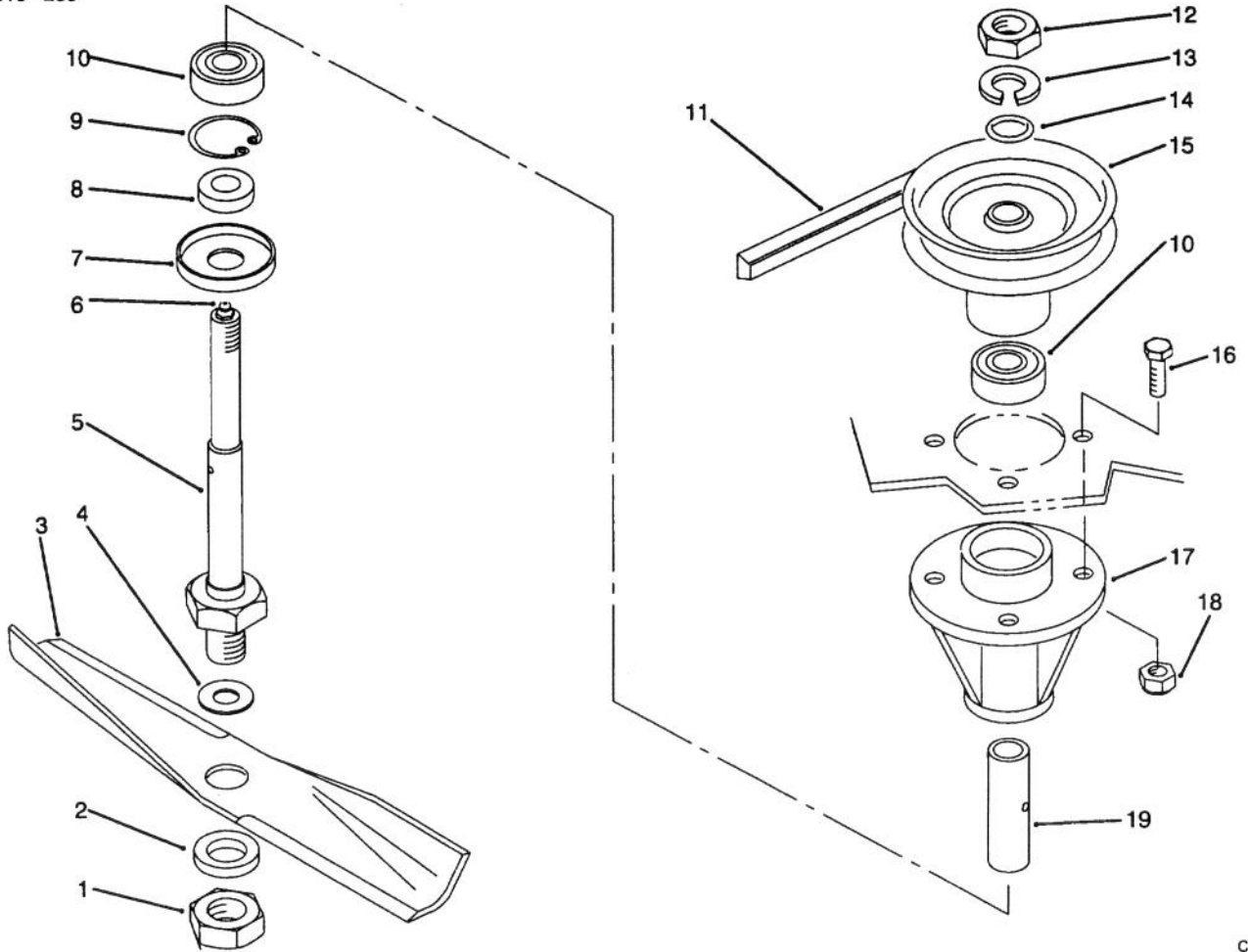

## SPINDLE ASSEMBLY

Ref. No.	Part No.	Description	No. Used
1	3220-7	Nut - Hex.	1
2	3256-28	Washer - Flat	1
3	106636	Kit - Blade (Set of 3)	1
4	92-0257	Washer	1
5	78-6710	Shaft - Spindle	1
6	302-5	Fitting - Grease	1
7	106077	Cup - Spindle	1
8	106068	Spacer	1
9	32120-42	Ring - Retaining	1

Ref. No.	Part No.	Description	No. Used
10	109966	Bearing	2
11	78-6240	V-Belt	1
12	3220-6	Nut - Hex.	1
13	3253-8	Washer - Lock	1
14	971015	O-Ring	1
15	78-1210	Pulley - Spindle	1
16	908032	Screw - Cap Hex. Hd.	4
17	114568	Housing - Spindle	1
18	3296-39	Nut - Lock	4
19	116085	Spacer	1

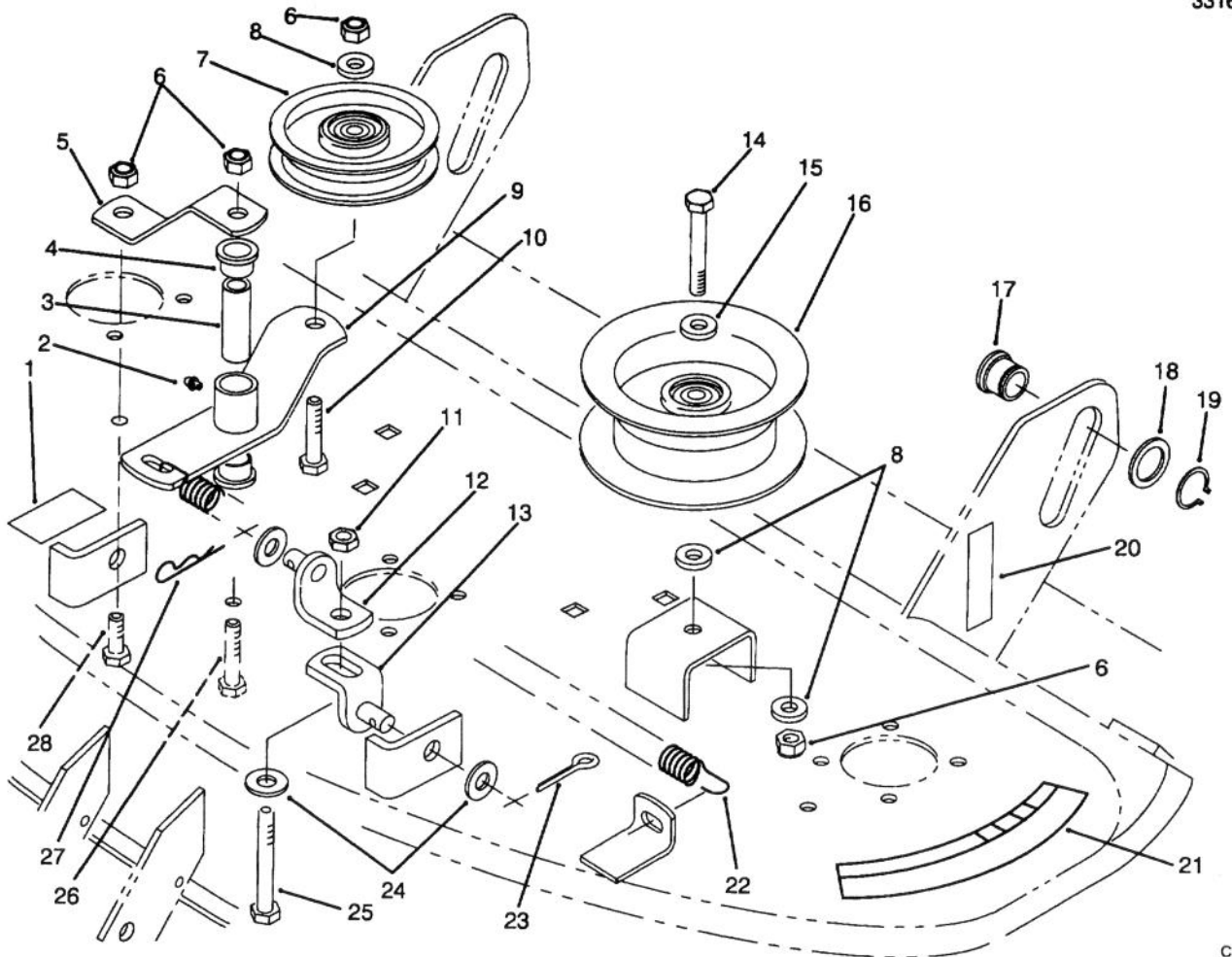

C-1642

## PULLEYS & IDLER ARM ASSEMBLY

Ref. No.	Part No.	Description	No. Used
1	116286	Decal - Belt Routing	1
2	302-26	Fitting - Grease	1
3	79-2760	Spacer	1
4	109859	Bushing	2
5	78-3140	Strap - Brace	1
6	3296-39	Nut - Lock	4
7	115119	Pulley - Idler	1
8	3256-24	Washer - Flat	3
9	78-3150	Arm W.A. - Idler	1
10	323-9	Screw - Cap Hex. Hd.	1
11	3218-5	Nut - Hex.	1
12	86-9250	Bracket W.A. - Lift, Upper	1
13	86-9240	Bracket W.A. - Lift, Lower	1
14	323-11	Screw - Cap Hex. Hd.	1

Ref. No.	Part No.	Description	No. Used
15	2844	Washer	1
16	78-8250	Pulley - Idler	1
17	78-7340	Roller - Lift	2
18	920239	Washer	2
19	32151-29	Ring - Retaining	2
20	115196	Decal - Attach-A-Matic	2
21	76-4070	Decal - Danger	1
22	116172	Spring - Extension	1
23	3272-21	Pin - Cotter	1
24	3256-26	Washer - Flat	3
25	325-13	Screw - Cap Hex. Hd.	1
26	323-14	Screw - Cap Hex. Hd.	1
27	933506	Pin - Cotter, Hair	1
28	323-6	Screw - Cap Hex. Hd.	1

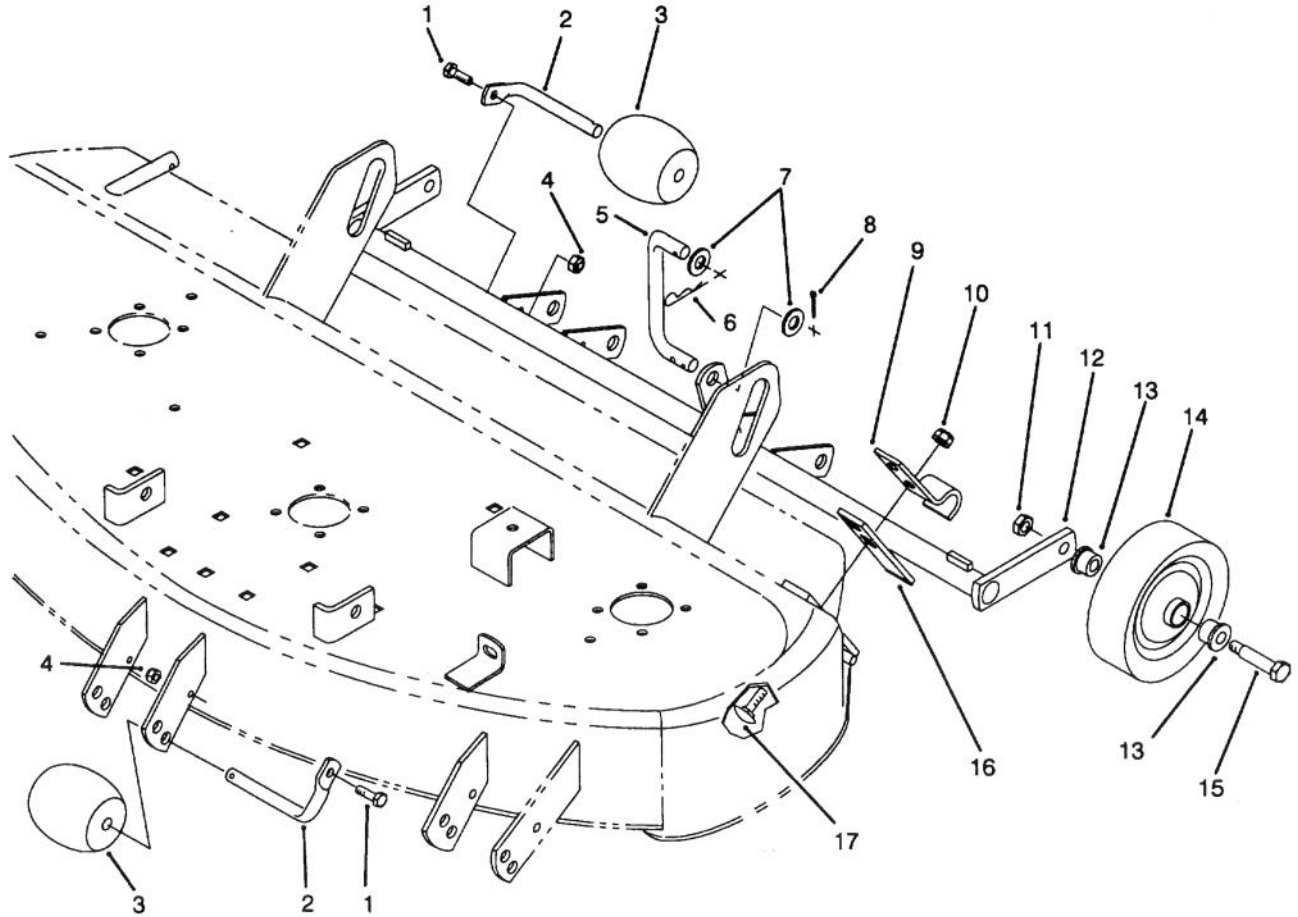

C-1644

## GAGE WHEEL & ROLLER ASSEMBLY

Ref. No.	Part No.	Description	No. Used	Ref. No.	Part No.	Description	No. Used
1	908004	Screw - Cap Hex. Hd.	5	11	32146-2	Nut - Hex.	2
2	118960	Shaft - Roller	5	12	78-6661	Support W.A. - Wheel, Gage	1
3	29-4820	Roller	5	13	5306	Bushing	4
4	3296-42	Nut - Lock	5	14	110506	Assembly - Wheel (Incl. Ref. #13)	2
5	78-6681	Link - Rear	1	15	5188	Bolt - Wheel	2
6	933507	Pin - Cotter, Hair	2	16	110838	Bar	2
7	3256-26	Washer - Flat	2	17	3231-4	Bolt - Carriage	2
8	3272-21	Pin - Cotter	1				
9	110837	Clamp	2				
10	3296-39	Nut - Lock	2				